

825 KVA DIESEL GENERATOR

FEATURES & BENEFITS

- Maximum 900 kVA, 380V, 1500 RPM
- Constant voltage AVR (Automatic Voltage Regulator)
- 24 Volt Electric Starter
- 995 Litre Fuel Tank, 8 Hours @ 75% load
- Silent Version (± 78 dBA)
- In-line, 4strokes, water-cooled, Turbo charged with aftercooler
- Three Phase Output
- DeepSea DSE6120 Digital Control Panel
- Low oil pressure system
- Low water cut out engine protection



GENERAL DATA	
Model:	BPD825S3
Prime Power (P.R.P):	825 kVA
Stand-by Power (L.T.P):	900 kVA
Amps:	1367 A
Power Factor / COS:	0.8
Frequency:	50 Hz
Voltage:	380 V
Phases:	Three Phase
Engine Speed:	1500 RPM
Length:	5200 mm
Width:	1850 mm
Height:	2320 mm
Weight:	6500 kg's
Tank Capacity:	995 l

ADDITIONAL	
Running Time:	8 Hours @ 75% load
Structure Type:	Silent
Noise Level (7m):	78 dBA
Auto Voltage Regulator:	Constant voltage AVR
ISO9001 Certified:	Yes
CE Certified:	Yes
Fuel Cons. @ 100% Load:	169
Fuel Cons. @ 75% Load:	124
Fuel Cons. @ 50% Load:	84

ENGINE DATA	
Brand:	SDEC
Model:	6KTAA25-G31
Type:	In-line, 4strokes, water-cooled, Turbo charged with aftercooler
Starting System:	24 Volt Electric Starter
Auto-Decompression:	Yes
Cubic Capacity (l):	25.18
Compression Ratio:	14.5:1
Rated Power (kW/RPM):	728 / 1500
Fuel Type:	Diesel
Lube Oil:	15W40
Low Pressure Alert:	Yes
Low Fuel Cut Out:	Yes

CONTROL PANEL	
Model:	DeepSea DSE6120
Type:	Digital Control Panel
Analogue Inputs:	2
Mains Phase Voltage:	Yes
Mains Line Voltage:	Yes

ALTERNATOR	
Model:	DPC-660
Pole Number:	4
Excitation Mode:	Self Excitation

Maputo, Moçambique

+258 85 176 3143

comercial@cobalt.co.mz

www.cobalt.co.mz



6KTAA25-G31

◎ Power

Engine Speed r/min	Type of Operation	Engine Power		Generator Power	
		kW	Ps	kW	kVA
1500	Prime Power	728	990	660	825
	Standby Power	170	1088	726	908

-. The engine performance is as per GB/T2820

-. Ratings are based on GB/T1147.1.

→**Prime Power** : --- There is no time limit in the case of variable load operation. In any 250hours of continuous operation period, the variable load of average work load less than 70%of the prime power. The operation time in the situation of 100%prime power no more than 500 hours. Permit 10%overload running1hours in any 12 hours of continuous operation period. The overload 10% power running time of every year no more than 25 hours..

→**Standby Power** : The annual total standby power load should be less than 80%and the average running time shall be less than200 hours. Among them the standby power point should be no more than 25 hours a year. .

◎ SPECIFICATIONS

○ Engine Model	6KTAA25-G31
○ Engine Type	In-line,4strokes, water-cooled, Turbo charged with aftercooler
○ Combustion type	Direct injection
○ Cylinder Type	Wet liner
○ Number of cylinders	6
○ Bore ×stroke	170 ×185 mm
○ Displacement	25.18L
○ Compression ratio	14.5 : 1
○ Firing order	1-5-3-6-2-4
○ Injection timing	Electronic control
○ Dry weight	Approx.2700kg
○ Dimension (L×W×H)	2055×1241×1936mm
○ Rotation	SAE NO.0
○ Fly wheel housing	SAE NO.18(tooth number of gear:143)

◎ MECHANISM

○ Type	Overhead valve
○ Number of valve	Intake 2, exhaust 2 per cylinder
○ Valve lashes at cold	Intake 0.35mm Exhaust 0.60mm

◎ VALVE TIMING

	Opening	Close
○ Intake valve	25° BTDC	57° ABDC
○ Exhaust valve	66° BBDC	16° ATDC

◎ COOLING SYSTEM

○ Cooling method	Fresh water forced circulation
------------------	--------------------------------

◎ FUEL CONSUMPTION

○ Power	L/h (1500r/min)
25%	47
50%	84
75%	124
100%	163
110%	178

◎ FUEL SYSTEM

○ Injection pump	Liebherr
○ Governor	Liebherr
○ Feed pump	Electronic Control
○ Injection nozzle	Multi hole type
○ Fuel filter	Full flow, cartridge type
○ Used fuel	Diesel fuel oil

◎ LUBRICATION SYSTEM

○ Lub. Method	Fully forced pressure feed type
○ Oil pump	Gear type driven by crankshaft
○ Oil filter	Full flow, cartridge type
○ Oil pan capacity	High level 75 liters Low level 45 liters
○ Angularity limit	Front down 12deg. Front up 15 deg. Side to side 35 deg.
○ Lub. Oil	Refer to Operation Manual

◎ ENGINEERING DATA

- Water capacity 55 liters
(engine only)
- Water pump Centrifugal type driven by belt
- Water pump Capacity 880L/min (1500r/min)
- Thermostat Wax-pellet type

Opening temp. 77°C
Full open temp. 90°C
- Cooling fan Blower type, plastic
1220 mm diameter, 8blades

Power consumption 22kw

- Air flow 3210m³/min (1500r/min)
- Exhaust gas flow 8330m³/min (1500r/min)
- Exhaust gas temp. 500 °C
- Max. permissible restrictions 2.5 kPa initial
6.2 kPa final (need charge filter element)
- Intake system
- Exhaust system 10 kPa max.
- Max. permissible altitude 2000 m
- intercooler permissible restrictions 10 kPa

◎ ELECTRICAL SYSTEM

- Charging generator 28V×55A
- Voltage regulator Built-in type IC regulator
- Starting motor 24V×9kW
- Battery Voltage 24V
- Battery Capacity 200 AH

◆ 换算表

in. = mm ×0.0394

PS = kW ×1.3596

psi = kg/cm² ×14.2233

in³ = L ×61.02

hp = PS ×0.98635

lb = kg ×2.20462

lb/PS.h = g/kW.h ×0.00162

cfm = m³/min ×35.336

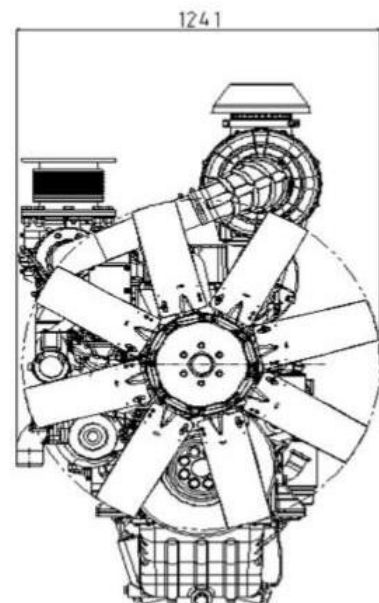
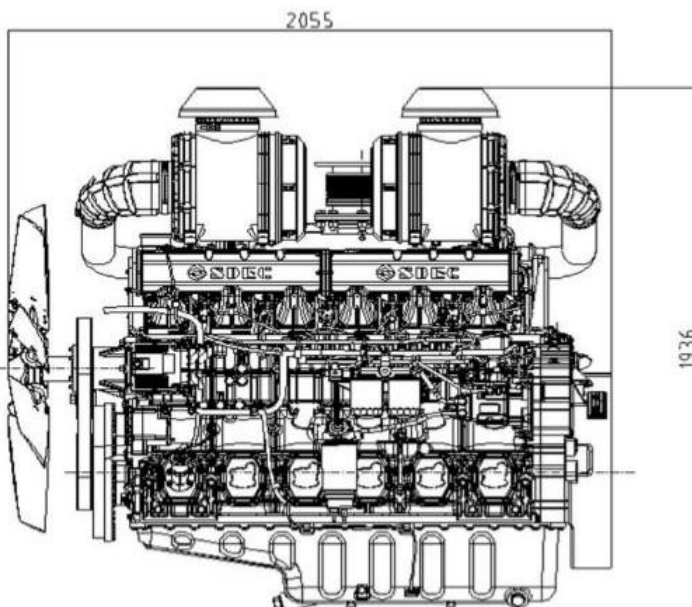

DSE6110/20 MKII

AUTO START & AUTO MAINS FAILURE CONTROL MODULES

DSE6110 MKII

DSE6120 MKII

KEY FEATURES

- Large back-lit text display
- Multiple display languages
- Heated display option available
- DSENet® expansion compatible
- Data logging facility
- Fully configurable via PC using USB communication
- Front panel configuration
- Efficient power save mode
- 3 phase generator sensing
- 3 phase mains (utility) sensing (DSE6120 MKII only)
- Generator/load power monitoring (kW, kV A, kV Ar, pf)
- Accumulated power monitoring (kW h, kVA h, kVAr h)
- Generator/load current monitoring and protection
- Generator overload protection (kW)
- Breaker control via fascia buttons
- Fuel and start outputs, configurable when using CAN
- 4 configurable DC outputs
- 4 configurable analogue/digital inputs
- Support for 0 to 10 V &

- 4 to 20 mA oil pressure sensors
- 6 configurable digital inputs
- Configurable staged loading outputs
- CAN, MPU and alternator speed sensing in one variant
- 3 engine maintenance alarms
- Engine speed protection
- Engine hours counter
- Engine pre-heat
- Engine run-time scheduler
- Engine idle control for starting & stopping
- Fuel pump control
- Real time clock
- Battery voltage monitoring
- Start on low battery voltage
- Configurable remote start input
- 1 alternative configuration
- Comprehensive warning, electrical trip or shutdown protection upon fault condition
- LCD and LED alarm indication
- Customisable information screens
- Configurable event log (100)
- Tier 4 ECO engine support including exhaust fluids & filters

- J1939-75 instrumentation output, configurable CAN instrumentation and alarms
- Start on low battery
- Enhanced alarm functionality
- Low load alarm

KEY BENEFITS

- Automatically transfers between mains (utility) and generator (DSE6120 MKII only)
- Increased input and output expansion capability via DSENet®
- User-friendly set-up and button layout for ease of use
- Multiple parameters are monitored simultaneously which are clearly displayed on a large back-lit text display via multiple languages
- The module can be configured to suit a wide range of applications
- Uses DSE Configuration Suite PC Software for simplified configuration
- Licence-free PC software
- IP65 rating (with optional gasket) offers increased resistance to water ingress

SPECIFICATIONS
DC SUPPLY
CONTINUOUS VOLTAGE RATING
 8 V to 35 V Continuous

CRANKING DROPOUTS

Able to survive 0 V for 50 mS, providing supply was at least 10 V before dropout and supply recovers to 5 V. This is achieved without the need for internal batteries. LEDs and backlight will not be maintained during cranking.

MAXIMUM OPERATING CURRENT

100 mA at 12 V, 105 mA at 24 V

MAXIMUM STANDBY CURRENT

60 mA at 12 V, 55 mA at 24 V

MAXIMUM SLEEP CURRENT

40 mA at 12 V, 35 mA at 24 V

GENERATOR & MAINS (UTILITY)
VOLTAGE RANGE
 15 V to 415 V AC (Ph to N)
 26 V to 719 V AC (Ph to Ph)

FREQUENCY RANGE

3.5 Hz to 75 Hz

INPUTS
DIGITAL INPUTS A to F

Negative switching

ANALOGUE INPUT A

 Configurable as:
 Negative switching digital input
 0 V to 10 V
 4 mA to 20 mA
 0 Ω to 240 Ω

ANALOGUE INPUTS B TO D

 Configurable as:
 Negative switching digital input
 0 Ω to 480 Ω

OUTPUTS
OUTPUT A (FUEL)

10 A short term, 5 A continuous, at supply voltage

OUTPUT B (START)

10 A short term, 5 A continuous, at supply voltage

AUXILIARY OUTPUTS C, D, E & F

2 A DC at supply voltage

DIMENSIONS
OVERALL
 216 mm x 158 mm x 43 mm
 8.5" x 6.2" x 1.5"

PANEL CUT-OUT

 184 mm x 137 mm
 7.2" x 5.3"

MAXIMUM PANEL THICKNESS

 8 mm
 0.3"

STORAGE TEMPERATURE RANGE

 -40 °C to +85 °C
 -40 °F to +185 °F

OPERATING TEMPERATURE RANGE
NON HEATED DISPLAY VARIANT
 -30 °C to +70 °C
 -22 °F to +158 °F

HEATED DISPLAY VARIANT

 -40 °C to +70 °C
 -40 °F to +158 °F

RELATED MATERIALS
TITLE

 DSE6110/20 MKII Installation Instructions
 DSE6110/20 MKII Operator Manual
 DSE6110/20 MKII Configuration Suite PC Manual

PART NO.

 053-173
 057-226
 057-224

OPTIONAL PARTS

PART	PART NUMBER
IP65 Gasket	020-521

DEEP SEA ELECTRONICS PLC UK

 Highfield House, Hunmanby Industrial Estate, Hunmanby YO14 0PH
TELEPHONE +44 (0) 1723 890099 **FACSIMILE** +44 (0) 1723 893303
EMAIL sales@deepseapl.com **WEBSITE** www.deepseapl.com

Deep Sea Electronics Plc maintains a policy of continuous development and reserves the right to change the details shown on this data sheet without prior notice. The contents are intended for guidance only.

DEEP SEA ELECTRONICS INC USA

 3230 Williams Avenue, Rockford, IL 61101-2668 USA
TELEPHONE +1 (815) 316 8706 **FACSIMILE** +1 (815) 316 8708
EMAIL sales@deepseausa.com **WEBSITE** www.deepseausa.com

 Registered in England & Wales No.01319649
 VAT No.316923457

DSE6110/20 MKII

AUTO START & AUTO MAINS FAILURE CONTROL MODULES

The DSE6110 MKII Auto Start Control Module and the DSE6120 MKII Auto Mains (Utility) Failure Control Module are suitable for a wide variety of single gen-set applications.

Monitoring engine speed, oil pressure, coolant temperature, frequency, voltage, current, power and fuel level, the modules give comprehensive engine and alternator protection. This is indicated on a large back-lit LCD text display via an array of warning, electrical trip and shutdown alarms in multiple languages.

Electronic J1939 (CAN) and non-electronic MPU and alternator sensing engine support for diesel, gas and petrol engines all in one variant. With a number of flexible inputs, outputs and protections, the modules can be easily adapted to suit a wide range of applications.

Through USB Communication both modules can be configured using the DSE Configuration Suite PC Software or through the module's front panel editor.

Using the DSE Configuration Suite PC Software the controller is easy to use and configure which allows alteration of operating parameters, sequences, timers and alarms.

AVAILABLE VARIANTS

- 6110-03 Auto Start with real time clock
- 6120-03 Auto Mains Failure with real time clock

ENVIRONMENTAL TESTING STANDARDS

ELECTRO-MAGNETIC COMPATIBILITY
 BS EN 61000-6-2
 EMC Generic Immunity Standard for the Industrial Environment
 BS EN 61000-6-4
 EMC Generic Emission Standard for the Industrial Environment

ELECTRICAL SAFETY
 BS EN 60950
 Safety of Information Technology Equipment, including Electrical Business Equipment

TEMPERATURE
 BS EN 60068-2-1
 Ab/Ae Cold Test -30 °C
 BS EN 60068-2-2
 Bb/Be Dry Heat +70 °C

VIBRATION
 BS EN 60068-2-6
 Ten sweeps in each of three major axes
 5 Hz to 8 Hz at +/-7.5 mm,
 8 Hz to 500 Hz at 2 GN

HUMIDITY
 BS EN 60068-2-30
 Db Damp Heat Cyclic 20/55 °C at 95% RH 48 Hours
 BS EN 60068-2-78
 Cab Damp Heat Static 40 °C at 93% RH 48 Hours

SHOCK
 BS EN 60068-2-27
 Three shocks in each of three major axes
 15 GN in 11 mS

DEGREES OF PROTECTION PROVIDED BY ENCLOSURES
 BS EN 60529
 IP65 - Front of module when installed into the control panel with the optional sealing gasket.

COMPREHENSIVE FEATURE LIST TO SUIT A WIDE VARIETY OF GEN-SET APPLICATIONS

